

FEATURES

- 3.3V and 5V power supply options
- 650ps propagation delay
- 4.0GHz toggle frequency
- High bandwidth output transistions
- Internal 75k Ω input pull-down resistors
- Available in 8-pin SOIC package

**Precision Edge[®]****DESCRIPTION**

The SY10/100EL33/L are integrated $\div 4$ dividers. The differential clock inputs and the VBB allow a differential, single-ended or AC-coupled interface to the device. If used, the VBB output should be bypassed to ground with a 0.01 μ F capacitor. Also note that the VBB is designed to be used as an input bias on the EL33/L only; the VBB output has limited current sink and source capability.

The reset pin is asynchronous and is asserted on the rising edge. Upon power-up, the internal flip-flops will attain a random state; the reset input allows for the synchronization of multiple EL33/Ls in a system.

PIN NAMES

Pin	Function
CLK	Clock Inputs
Reset	Asynchronous Reset
VBB	Reference Voltage Output
Q	Data Outputs

PACKAGE/ORDERING INFORMATION

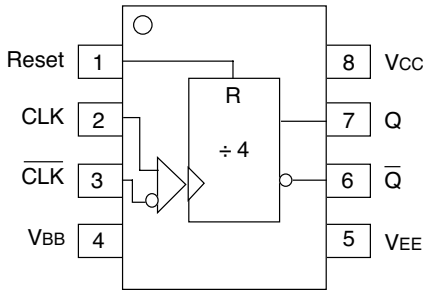

8-Pin SOIC (Z8-1)

Ordering Information⁽¹⁾

Part Number	Package Type	Operating Range	Package Marking	Lead Finish
SY10EL33ZC	Z8-1	Commercial	HEL33	Sn-Pb
SY10EL33ZCTR ⁽²⁾	Z8-1	Commercial	HEL33	Sn-Pb
SY100EL33ZC	Z8-1	Commercial	XEL33	Sn-Pb
SY100EL33ZCTR ⁽²⁾	Z8-1	Commercial	XEL33	Sn-Pb
SY10EL33ZI	Z8-1	Industrial	HEL33	Sn-Pb
SY10EL33ZITR ⁽²⁾	Z8-1	Industrial	HEL33	Sn-Pb
SY100EL33ZI	Z8-1	Industrial	XEL33	Sn-Pb
SY100EL33ZITR ⁽²⁾	Z8-1	Industrial	XEL33	Sn-Pb
SY10EL33LZC	Z8-1	Commercial	HEL33L	Sn-Pb
SY10EL33LZCTR ⁽²⁾	Z8-1	Commercial	HEL33L	Sn-Pb
SY100EL33LZC	Z8-1	Commercial	XEL33L	Sn-Pb
SY100EL33LZCTR ⁽²⁾	Z8-1	Commercial	XEL33L	Sn-Pb
SY10EL33LZI	Z8-1	Industrial	HEL33L	Sn-Pb
SY10EL33LZITR ⁽²⁾	Z8-1	Industrial	HEL33L	Sn-Pb
SY100EL33LZI	Z8-1	Industrial	XEL33L	Sn-Pb
SY100EL33LZITR ⁽²⁾	Z8-1	Industrial	XEL33L	Sn-Pb
SY10EL33ZG ⁽³⁾	Z8-1	Industrial	HEL33 with Pb-Free bar-line indicator	Pb-Free NiPdAu
SY10EL33ZGTR ^(2, 3)	Z8-1	Industrial	HEL33 with Pb-Free bar-line indicator	Pb-Free NiPdAu
SY100EL33ZG ⁽³⁾	Z8-1	Industrial	XEL33 with Pb-Free bar-line indicator	Pb-Free NiPdAu
SY100EL33ZGTR ^(2, 3)	Z8-1	Industrial	XEL33 with Pb-Free bar-line indicator	Pb-Free NiPdAu
SY10EL33LZG ⁽³⁾	Z8-1	Industrial	HEL33L with Pb-Free bar-line indicator	Pb-Free NiPdAu
SY10EL33LZGTR ^(2, 3)	Z8-1	Industrial	HEL33L with Pb-Free bar-line indicator	Pb-Free NiPdAu
SY100EL33LZG ⁽³⁾	Z8-1	Industrial	XEL33L with Pb-Free bar-line indicator	Pb-Free NiPdAu
SY100EL33LZGTR ^(2, 3)	Z8-1	Industrial	XEL33L with Pb-Free bar-line indicator	Pb-Free NiPdAu

Notes:

1. Contact factory for die availability. Dice are guaranteed at T_A = 25°C, DC Electricals only.
2. Tape and Reel.
3. Pb-Free package is recommended for new designs.

DC ELECTRICAL CHARACTERISTICS⁽¹⁾

VEE (Min) to VEE (Max); VCC = GND

Symbol	Parameter	TA = -40°C			TA = 0°C			TA = +25°C			TA = +85°C			Unit
		Min.	Typ.	Max.	Min.	Typ.	Max.	Min.	Typ.	Max.	Min.	Typ.	Max.	
IEE	Power Supply Current													mA
	10EL	—	27	33	—	27	33	—	27	33	—	27	33	
	100EL	—	27	33	—	27	33	—	27	33	—	31	37	
VBB	Output Reference Voltage													V
	10EL	-1.43	—	-1.30	-1.38	—	-1.27	-1.35	—	-1.25	-1.31	—	-1.19	
	100EL	-1.38	—	-1.26	-1.38	—	-1.26	-1.38	—	-1.26	-1.38	—	-1.26	
I _{IH}	Input HIGH Current	—	—	150	—	—	150	—	—	150	—	—	150	μA

Note:

- Parametric values specified at:

5 volt Power Supply Range	100EL33 Series:	-4.2V to -5.5V.
	10EL33 Series	-4.75V to -5.5V.
3 volt Power Supply Range	10/100EL33L Series:	-3.0V to -3.8V.

AC ELECTRICAL CHARACTERISTICS⁽¹⁾

VEE (Min) to VEE (Max); VCC = GND

Symbol	Parameter	TA = -40°C			TA = 0°C			TA = +25°C			TA = +85°C			Unit
		Min.	Typ.	Max.	Min.	Typ.	Max.	Min.	Typ.	Max.	Min.	Typ.	Max.	
f _{MAX}	Maximum Toggle Frequency	3.4	4.2	—	3.8	4.2	—	3.8	4.2	—	3.8	4.2	—	GHz
t _{PD}	Prop. Delay to Output D Reset to Q	490	630 310	770 460	540 610	630 360	720 460	550 560	640 360	730 460	590 560	670 380	760 480	ps 580
V _{PP}	Minimum Input Swing ⁽²⁾	150	—	—	150	—	—	150	—	—	150	—	—	mV
t _r t _f	Output Rise/Fall Times Q (20% to 80%)	100	225	350	100	225	350	100	225	350	100	225	350	ps

Notes:

- Parametric values specified at:

5 volt Power Supply Range	100EL33 Series:	-4.2V to -5.5V.
	10EL33 Series	-4.75V to -5.5V.
3 volt Power Supply Range	10/100EL33L Series:	-3.0V to -3.8V.
- Minimum input swing for which AC parameters are guaranteed.

8-PIN SOIC .150" WIDE (Z8-1)

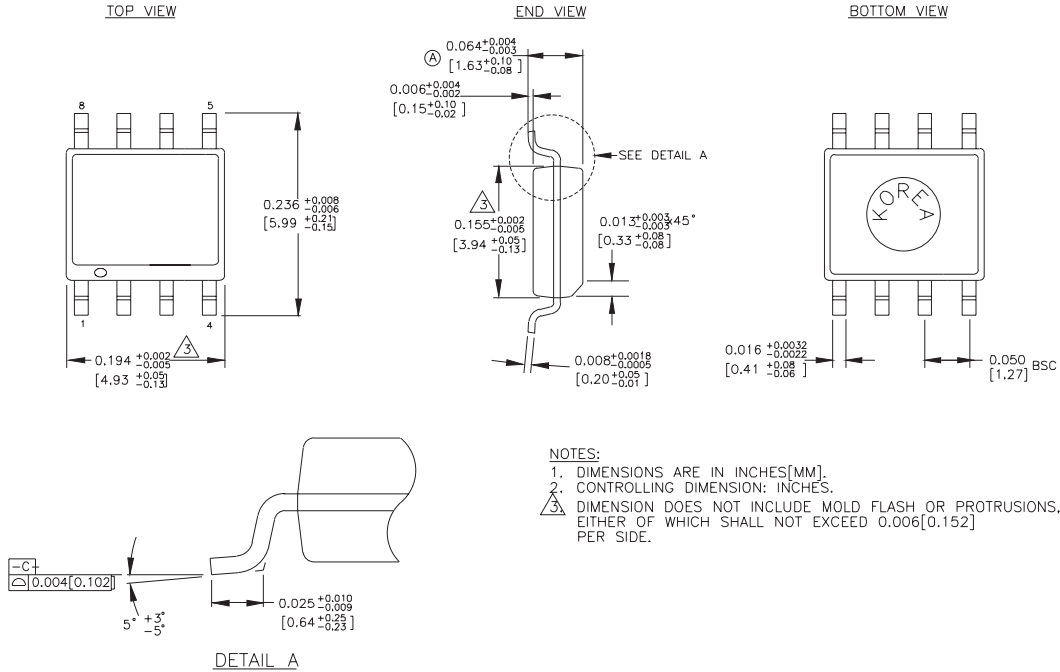

Rev. 03

MICREL, INC. 2180 FORTUNE DRIVE SAN JOSE, CA 95131 USA

TEL + 1 (408) 944-0800 FAX + 1 (408) 474-1000 WEB <http://www.micrel.com>

The information furnished by Micrel in this datasheet is believed to be accurate and reliable. However, no responsibility is assumed by Micrel for its use. Micrel reserves the right to change circuitry and specifications at any time without notification to the customer.

Micrel Products are not designed or authorized for use as components in life support appliances, devices or systems where malfunction of a product can reasonably be expected to result in personal injury. Life support devices or systems are devices or systems that (a) are intended for surgical implant into the body or (b) support or sustain life, and whose failure to perform can be reasonably expected to result in a significant injury to the user. A Purchaser's use or sale of Micrel Products for use in life support appliances, devices or systems is at Purchaser's own risk and Purchaser agrees to fully indemnify Micrel for any damages resulting from such use or sale.

© 2005 Micrel, Incorporated.